

AIP-IPFramer

IP packet formatting for IPv4 and IPv6

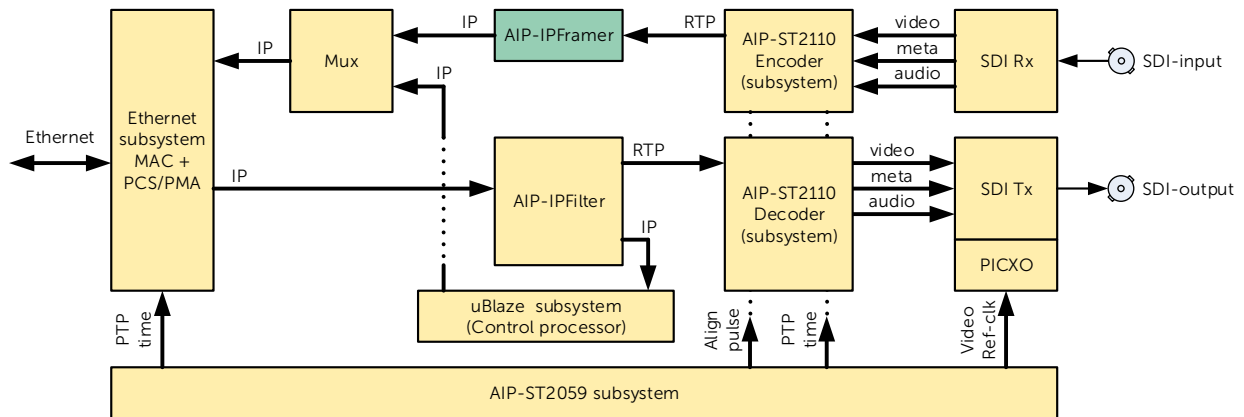

Figure 1: Application example

The AIP-IPFramer is an FPGA IP core that handles the formatting of UDP/IP packets in a multi-channel system. It is optimized but not limited to be used in a professional video over IP environment, e.g. in combination with the professional media over IP standard SMPTE-ST2110 and timing standard SMPTE-ST2059.

Product Description

The IP core formats RTP packets into UDP packets. It assembles and adds UDP, IP and MAC headers to the packets. It is able to calculate and insert CRC checksums, Vlan tag headers and specific MAC header commands.

Based on standard AXI4-Stream and AXI4-Lite interfaces, the AIP-IPFramer core can easily be integrated into your system design. RTL and SW drivers are included.

Key Features & Benefits

- Supports IPv4 and IPv6
- Supports Vlan tagging
- High performance for small and large packets up to MTU of 1500.

Available Demo designs

- The core is used in a combined SMPTE-ST2059 and SMPTE-ST2110 demo design.

Available documentation

- Product guide

Available licenses

- Site license
- Multi-site license
- Source code license