

# AIP-ST2110

## Professional Media Over Managed IP Networks

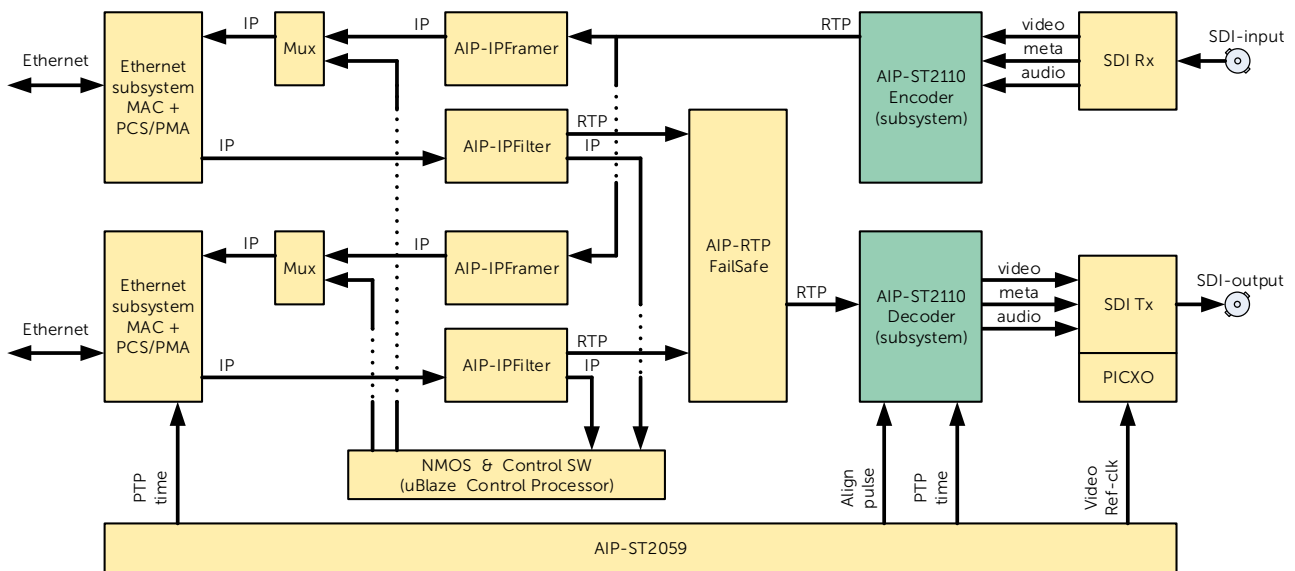

Figure 1: Application example

The AIP-ST2110 is an FPGA IP core that enables sending and/or receiving professional media, such as audio, video and/or metadata over IP networks. It is typically to be used in conjunction with the ST2059 time synchronisation standard. The ST2110 standard is defined by the Society of Motion Picture and Television Engineers.

## Product Description

The IP core provides broadcast and professional AV equipment the ability to send and/or receive professional media over IP networks.

The ST2110 standard is split up into multiple sub-standards, or dash-numbers. The following dash numbers are supported.

- ST2110-10: System timing
- ST2110-20: Uncompressed active video
- ST2110-21: Traffic shaping
- ST2110-22: Compressed video
- RP2110-23: 1 Stream over Multiple Links
- ST2110-30: PCM digital audio
- ST2110-31: AES3 transparent transport
- ST2110-40: Ancillary data

Based on standard AXI4-Stream, AXI4-Lite and AXI4-MM interfaces, the AIP-ST2059 core can easily be integrated into your system design. The RTL core is controlled by SW drivers and an ST2110 daemon, which are included.

## Key Features & Benefits

- Modular ST2110 encoder and decoder subsystems allow for easy system customization and optimization

- Supports gateway and synthetic essence operation
- Functionality is tested during official interoperability testing events
- The AIP-ST2110 core is network speed independent, so can be used in 1G, 10G, 25G and 100G Ethernet networks

## Available demo design

- Based on Xilinx development kits
- Supports 10 and 25 Gb/s Ethernet network
- Including ST2059 time synchronisation and NMOS control
- Control SW running on a MicroBlaze softcore processor on Peta Linux OS

## Available documentation

- Product guide
- Application note

## Available licenses

- Site license
- Multi-site license
- Source code license